

# Roof Valve Static Ventilator

Refer to product table below for applicable product codes covered by this document

Issue **D**

## Product Type & Application

The Bradford Ventilation Roof Valve is a low-profile static roof ventilator that allows the release of air from the roof space or internal space via flexible duct. The Bradford Roof Valve is suitable for residential, non-cyclonic, non-BAL applications.

## Compliance with the NCC

For use in Australia, when correctly specified and installed, this product provides the following compliance:

### NCC2022

- **Exhaust Systems** - When used with ducting, this product may be suitable to facilitate compliance with NCC 2022 Volume 1 F8D4(2) or (3) and ABCB Housing Provisions Standard 2022 10.8.2(2) or (3) by providing a ventilation path to outdoor air. Note that the product is not a powered exhaust system for compliance with NCC 2022 Volume 1 F8D4(1) and ABCB Housing Provisions Standard 2022 10.8.2(1) – its suitability should be independently verified prior to use.

Alternately, when used without ducting-

- **Ventilation of Roof Spaces** - Meets the requirements of NCC2022 Volume 1 F8D5 and ABCB Housing Provisions Standard 2022 10.8.3 as a Deemed to Satisfy solution for condensation management for NCC Climate Zones 6, 7 and 8.
- **Weatherproofing** - Meets the requirements of the NCC 2022 Volume 2 Weatherproofing Performance Requirement H2P2 via Deemed-to-Satisfy (DtS) and performance solution pathways.
- **Flashing** - Meets the requirement of ABCB Housing Provisions Standard 2022 7.3.3(3) as a Deemed-To-Satisfy flashing solution.

### NCC2019

- **Exhaust Systems** - When used with ducting this product may be suitable to facilitate compliance with NCC 2019 Volume 1 Amdt. 1 F6.3(b) or (c)(i) and NCC 2019 Volume 2 Amdt. 1 3.8.7.3(b)(i) by providing a ventilation path to outdoor air. Note that the product is not a powered exhaust system for compliance with NCC 2019 Volume 1 Amdt. 1 F6.3(a) or NCC 2019 Volume 2 Amdt. 1 3.8.7.3(a) – its suitability should be independently verified prior to use.

Alternately, when used without ducting-

- **Ventilation of Roof Spaces** - Meets the requirements of the NCC2019 Volume 1 Amend.1 F6.4 and NCC 2019 Volume 2 Amend.1 3.8.7.4 as a Deemed-To-Satisfy solution.
- **Weatherproofing** - Meets the requirements of the NCC 2019 Volume 2 Amend. 1 Weatherproofing Performance Requirement P2.2.2 via Deemed-to-Satisfy (DtS) and performance solution pathways.

## Compliance with the NCC cont.

- **Flashing** - Meets the requirement of NCC 2019 Volume 2 Amend. 1 3.5.2.3 (b) as a Deemed-To-Satisfy flashing solution.

## Evidence of Suitability

- Ventilation of roof spaces - Bradford Ventilation DTS Solution Calculation.
- Weatherproofing - Arcadis Report 30051677\_4.

## Limitations of Use

- **IMPORTANT** - Do Not Modify This Product: Compliance with the evidence of suitability data referenced in this document is only achieved by the product or configuration listed in this PTS.
- This product has not been tested for use in cyclonic wind regions C or D.
- Do not use for exhausting hazardous, abrasive, acidic and alkaline vapour or areas containing explosive or corrosive materials.
- This product is not suitable for use in Bush Fire BAL-12.5 to BAL-40 or BAL-FZ rated areas.
- Duct or connect only one Roof Valve per bathroom/laundry vent.
- When connected to powered fan applications, consult with fan manufacturer and product airflow performance graph within this PTS document.

## Conditions of Storage, Use & Maintenance

- Store in the original packaging in a cool and dry area. Do not attempt to repair – contact Bradford Ventilation for service advice.

## Specific Design or Installation Instructions

- Isolate power before installation.
- This product requires specific areas to be sealed against water entry and other areas to be left unsealed to allow internal condensation drainage – refer to the installation guide for details.
- Recommended Roof Valve positioning (refer also to NCC requirements below):
  - Tiled Roof: Between third and fourth row of tiles from the ridge cap.
  - Metal Roof: Ideally at the ridge cap but no lower than 1.2m from the ridge cap.
- Installation must be in accordance with the Bradford Ventilation Roof Valve Installation Instruction.
- Refer to the tables below for recommended ventilation levels. Note that there are differences in requirements between NCC 2019 and NCC 2022.

## Roof Valve Static Ventilator

### Specific Design or Installation Instructions cont.

- When used in conjunction with flexible ducting to ventilate an internal space, consideration should be given to the pressure loss associated with the Roof Valve and length of flexible duct.

For general installation guidance refer to the product installation guide at [www.bradfordventilation.com.au](http://www.bradfordventilation.com.au)

### Specific Design or Installation Instructions cont.

#### NCC2022 Ventilation of Roof Spaces Deemed-To-Satisfy Solution Requirements Calculation in Table 1:

The table below indicates the ventilation opening requirements for condensation management in NCC Climate Zones 6, 7 and 8. The NCC gives an open area requirement per meter length of the longest horizontal dimension (e.g., the longest length of gutter) of the roof, the table indicates how many products are required based on this. Ventilation openings should be evenly distributed.

Roof Valve vents should be installed not more than 900mm below the ridge or highest point of the roof space, measured vertically.

**Table 1. NCC 2022 Bradford Deemed-To-Satisfy Solution**

Products	Roof Valve Static Ventilator Requirement	Bradford Metal Eave Vent Requirement	Bradford Poly Eave Vent Requirement
Roof Pitch			
<10°		Install 1 Metal Eave Vent for every <b>0.7m</b> of the longest horizontal roof length. These must be equally divided between the two opposing ends of the roof.	Install 1 Poly Eave Vent for every <b>0.4m</b> of the longest horizontal roof length. These must be equally divided between the two opposing ends of the roof.
≥10° and <15°	1 Roof Valve for every <b>3.5m</b> of the longest horizontal roof length.	1 Metal Eave Vent for every <b>1.4m</b> of the longest horizontal roof length.	1 Poly Eave Vent for every <b>0.9m</b> of the longest horizontal roof length.
≥15° and <75°	1 Roof Valve for every <b>3.5m</b> of the longest horizontal roof length.	1 Metal Eave Vent for every <b>5.0m</b> of the longest horizontal roof length.	1 Poly Eave Vent for every <b>3.3m</b> of the longest horizontal roof length.
≥15° and <75° Cathedral	1 Roof Valve for every <b>3.5m</b> of the longest horizontal roof length.	1 Metal Eave Vent for every <b>1.4m</b> of the longest horizontal roof length.	1 Poly Eave Vent for every <b>0.9m</b> of the longest horizontal roof length.

**IMPORTANT APPLICATION NOTE:** The number of vents required should be rounded up, not down, to ensure that the ventilation provided meets or exceeds the recommended requirement. For example, the ventilation requirement for a 10° pitched roof 20m long in the longest horizontal direction is calculated as follows:

- The ventilator requirement (1 per 3.5m) is calculated as follows: 20m divided by the recommended Roof Valve Static spacing of 3.5m =  $20/3.5 = 5.7$  vents which should be rounded up to 6 Roof Valve Static Vents, to be evenly distributed along the roof.
- The metal eave vent requirement (1 per 1.4m) is calculated as follows: 20m divided by the recommended metal eave vent spacing of 1.4m =  $20/1.4 = 14.2$  eave vents which should be rounded up to 16 metal eave vents, evenly distributed around the roof.

#### NCC2019 Ventilation of Roof Spaces Deemed-To-Satisfy Solution Requirements Calculation in Table 2:

The table below indicates the ventilation opening requirements for condensation management in all NCC Climate Zones when kitchen, bathroom, sanitary compartment or laundry exhaust systems are discharging into the roof space.

- Calculate the area (m<sup>2</sup>) of ceiling directly under the roof space;
- Determine the pitch of the roof;
- Look-up the recommended number of Roof Valves and Bradford metal eave vents in the Deemed-To-Satisfy Solution Table below;
- Distribute the Roof Valves and Bradford Metal Eave Vents evenly.

## Roof Valve Static Ventilator

**Table 2. NCC 2019 Bradford Deemed-To-Satisfy Solution**

Roof Pitch	Total Ceiling Area (m <sup>2</sup> )	Number of Roof Valve required	Bradford Metal Eave Vents required	Bradford Poly Eave Vents required
> 22°	17	1	2	2
	35	2	3	4
	53	3	4	6
	71	4	5	7
	88	5	6	9
	106	6	8	11
	124	7	9	13

Total Ceiling Area is defined as the total ceiling area directly under the roof/attic space.

Where the roof pitch is  $\leq 22^\circ$ , the number of ventilators and eave vents specified must be doubled for the same ceiling area.

### Applicable Product Codes (SKU)

Night Sky 466758	Clear 468467
---------------------	-----------------

### Product Specifications

General	
Ventilator Type	Static Ventilator
Head Diameter	259 mm
Throat Diameter	150 mm
Minimum Open Area	17783 mm <sup>2</sup>
Product Weight	0.8 kg
Roof Slope Installation Range	Tiled Roofs 15° to 35° Metal Sheet Roofs 3° to 35° Note: Where applicable all roof pitches must comply to AS1562.1, the NCC & Australian Standards weatherproofing requirements within the ranges above.

Material	
Ventilator Head	ASA
Flashing	Aluminium (0.7mm thickness)

# Roof Valve Static Ventilator

## Product Airflow Performance – Static Ventilator

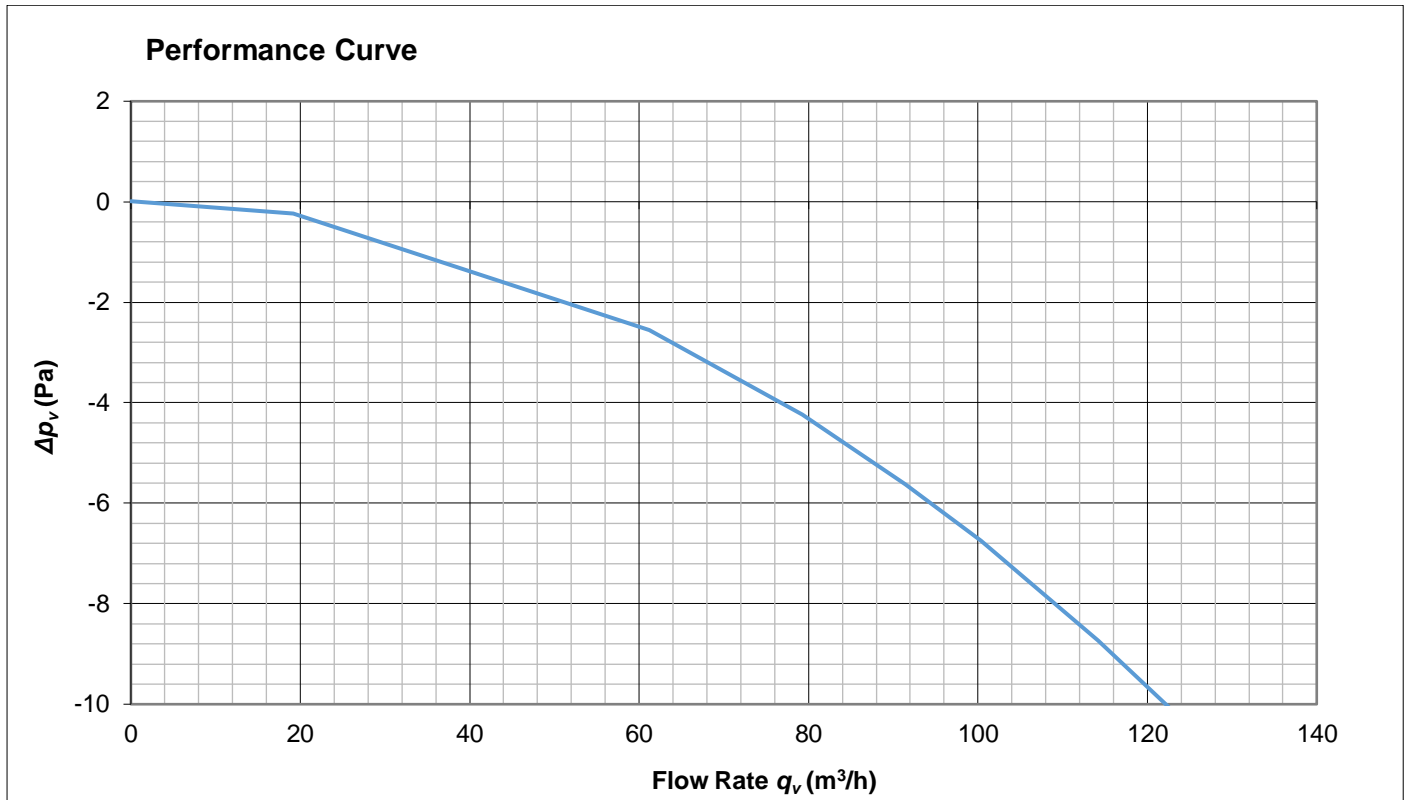

## Product Dimensions (in mm)

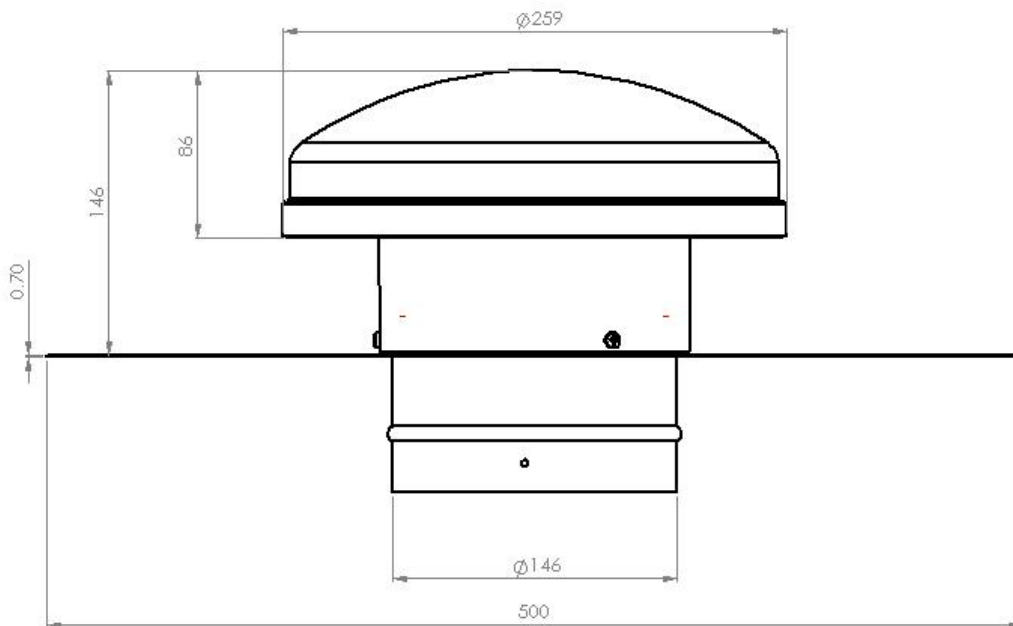

## Roof Valve Static Ventilator

### Product Assembly Dimensions (in mm)

